



Congratulations on your selection to purchase an Arnott Air Suspension System. We at Arnott Air Suspension Systems are proud to offer a high quality product at the industries most competitive pricing. Thank you for your confidence in us and our product.

Proper installation is essential to experience and appreciate the benefits of this system. Please take a moment to review these installation instructions before you begin to install this system on your vehicle.

It is equally important to be aware of all necessary safety measures while installing your new Air Ride System. This includes proper lifting and immobilizing of the vehicle and isolation of any stored energy to prevent personal injury or property damage.

*“Engineered to Ride, Built to last”*



**WARNING:** The air suspension system may be under pressure (up to 10 bar, or 150 lbf/in ) verify pressure has been relieved and disconnect power to the air ride system prior to disassembly. Do not allow dirt or grease to enter the system. Always wear standard protective hand, ear, and eye protection when servicing the air suspension system.

**Kit contains:**

**PARTS LIST**

P/N	QTY	DESCRIPTION
21-4808	1	FRONT AIR SPRING ASSEMBLY, RIGHT
21-4828	1	FRONT AIR SPRING ASSEMBLY, LEFT
29-3561*	2	RUBBER ROD END MOUNT
29-4832*	2	O-RING, TOP MOUNT
29-4833*	2	O-RING, SHOCK
14-3786*	2	BUMP STOP
29-4101*	8	M8x1.25x20mm LG HEX HEAD FLANGE BOLT

\*Items are kitted under part number 21-4682, 1 kit included.

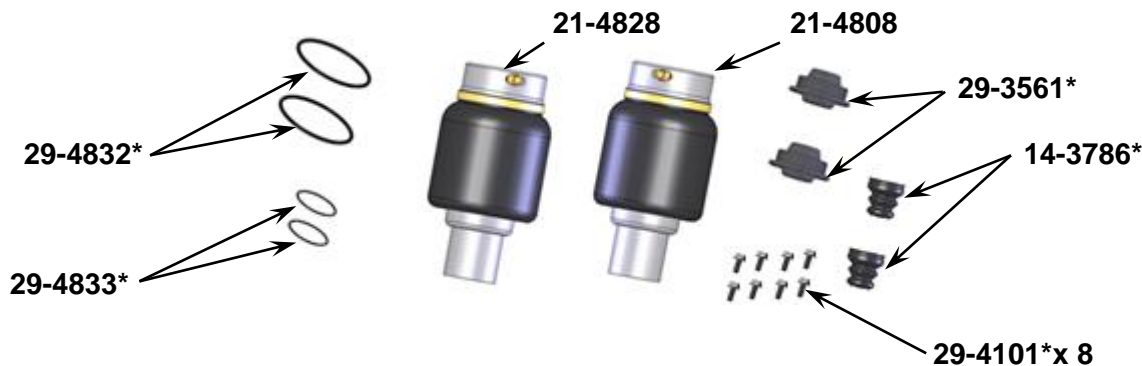



## Front shock removal:

**!** *WARNING: Air springs must be changed in pairs!*

**!** *The ignition must remain switched off during the shock removal and replacement.*

- 1.0 Set steering to straight ahead.
- 2.0 Remove fuse no. 27 (level control) in the fuse box on the right side of the dashboard.



**!** *Use lifting platform (hoist) that is capable of raising the body separately from the wheels, lift body at the lifting points prescribed by the vehicle manufacturer.*

*Vehicle slippage can cause danger to life and limb.*

- 3.0 Raise vehicle, check owner's manual for lifting points.
- 4.0 Remove front tire (procedure is the same for either side).
- 5.0 Remove air line from the shock at the air fitting. New air valve supplied with air spring (Figure A).

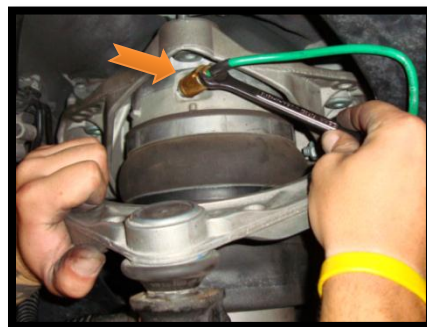

**Figure A**



6.0 Remove the lower shock-mounting bolt (Figure B).



**Figure B**

7.0 Remove the shock top mount from the control arm (Figure C).

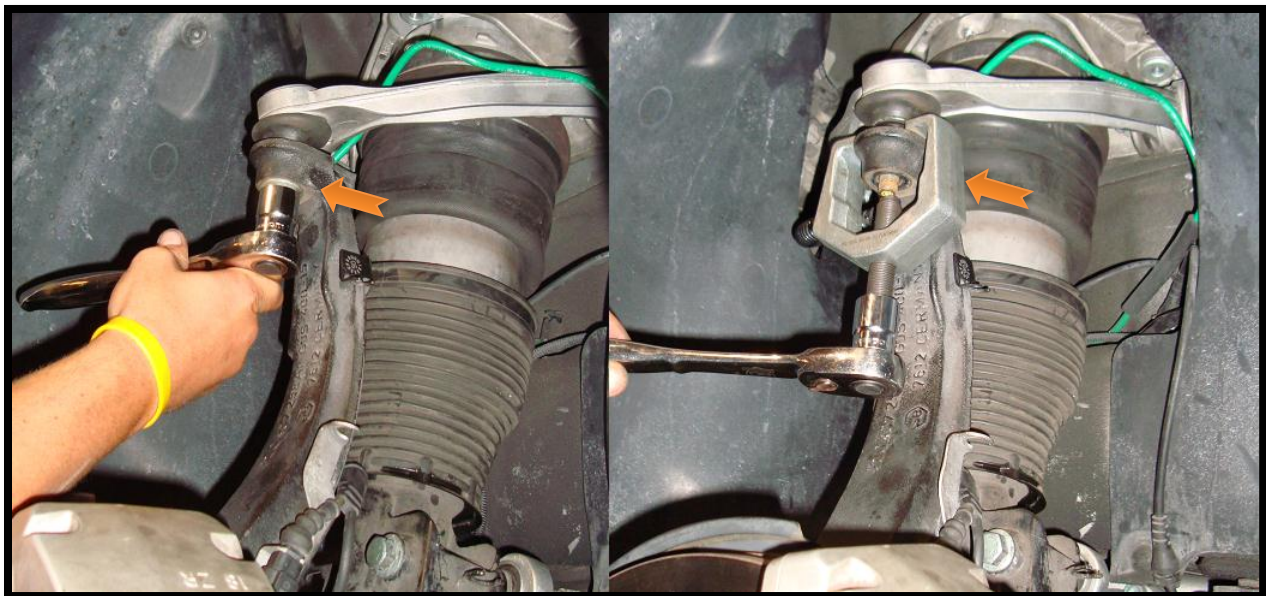

**Figure C**



8.0 Remove the sway bar link to shock mounting bolt (Figure D).

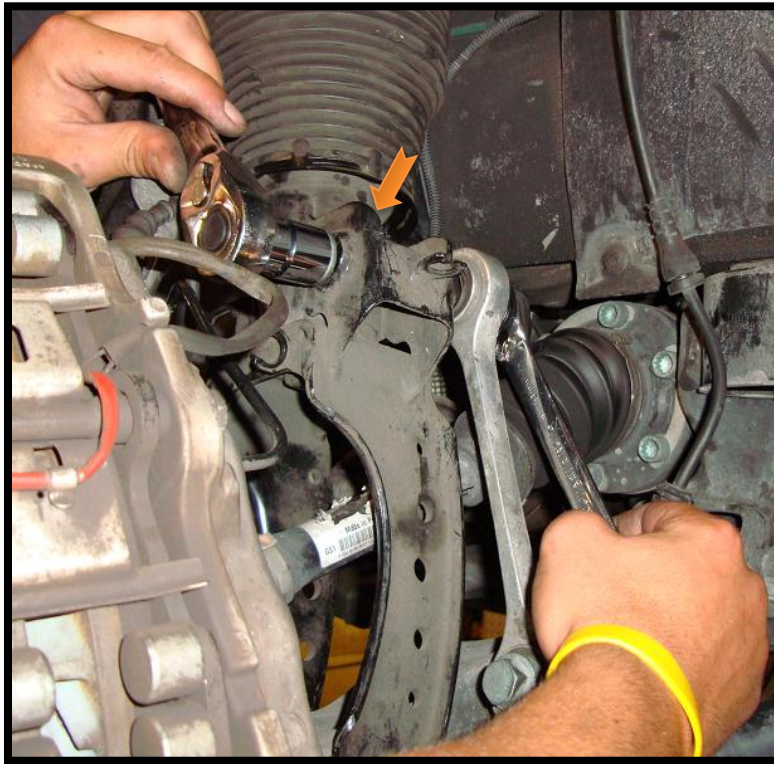

**Figure D**

9.0 Disconnect the travel linkage sensor connector (Figure E).

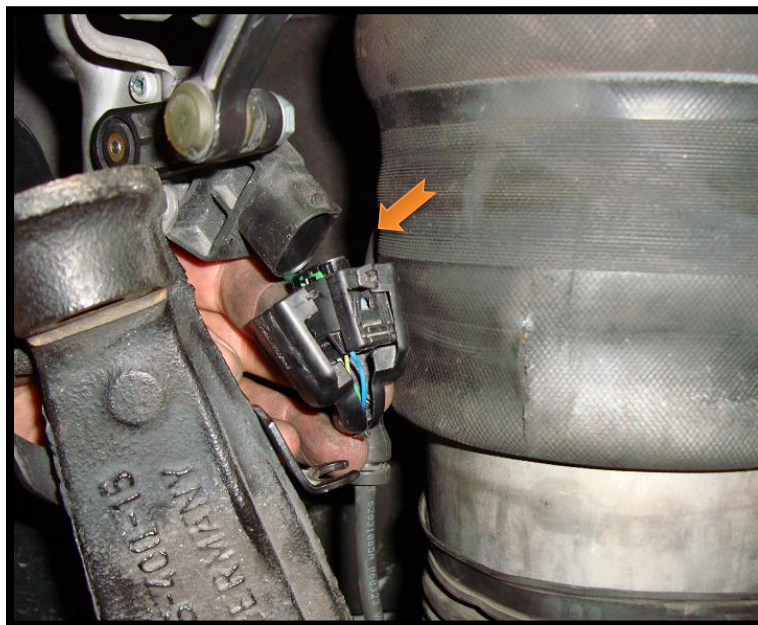

**Figure E**



- 10.0 Lift hood and remove the three (3) mounting bolts that secure the shock. Remove plastic cover to gain access to the third bolt (Figure F).

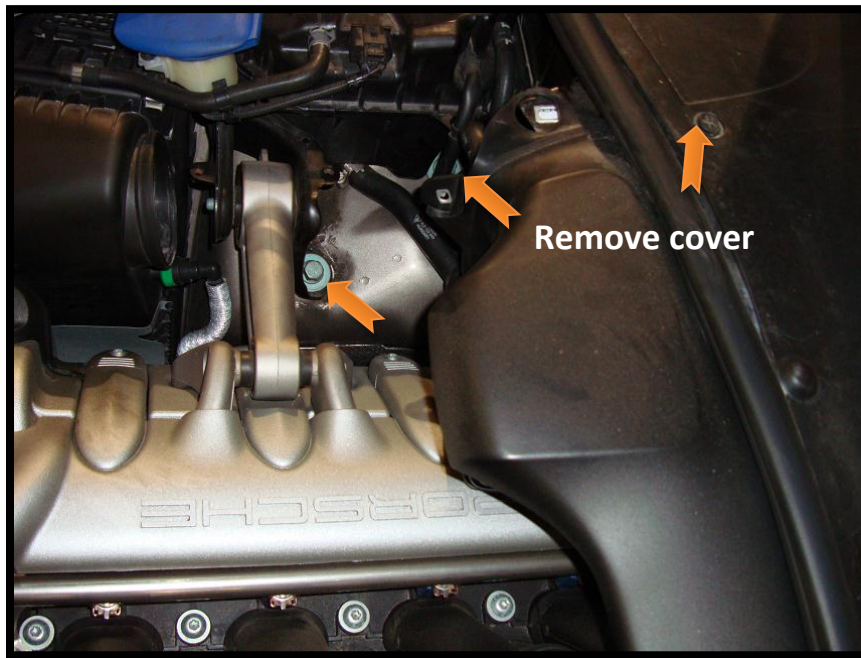

**Figure F**

- 11.0 Remove shock from the vehicle (Figure G).

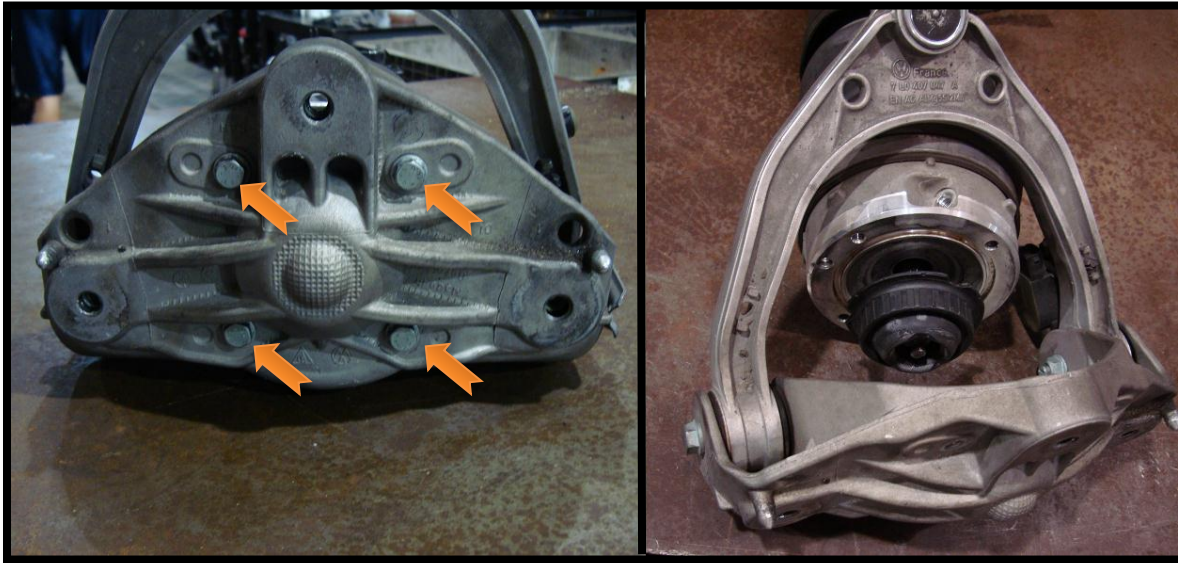

**Figure G**



**WARNING: AIR SPRING MAY BE UNDER PRESSURE USE CAUTION WHEN REMOVING THE AIR SPRING MOUNT FROM THE AIR SPRING. LOOSEN THE BOLTS AND LET THE PRESSURE BLEED OFF BEFORE REMOVING ALL BOLTS.**

- 12.0 Remove and discard the four bolts securing the air spring to the air spring mount. (Figure H).



**Figure H**

- 13.0 Remove and discard the old O-ring from the top mount. Remove nut from the air spring, remove, and discard the old rubber rod end mount (Figure I).

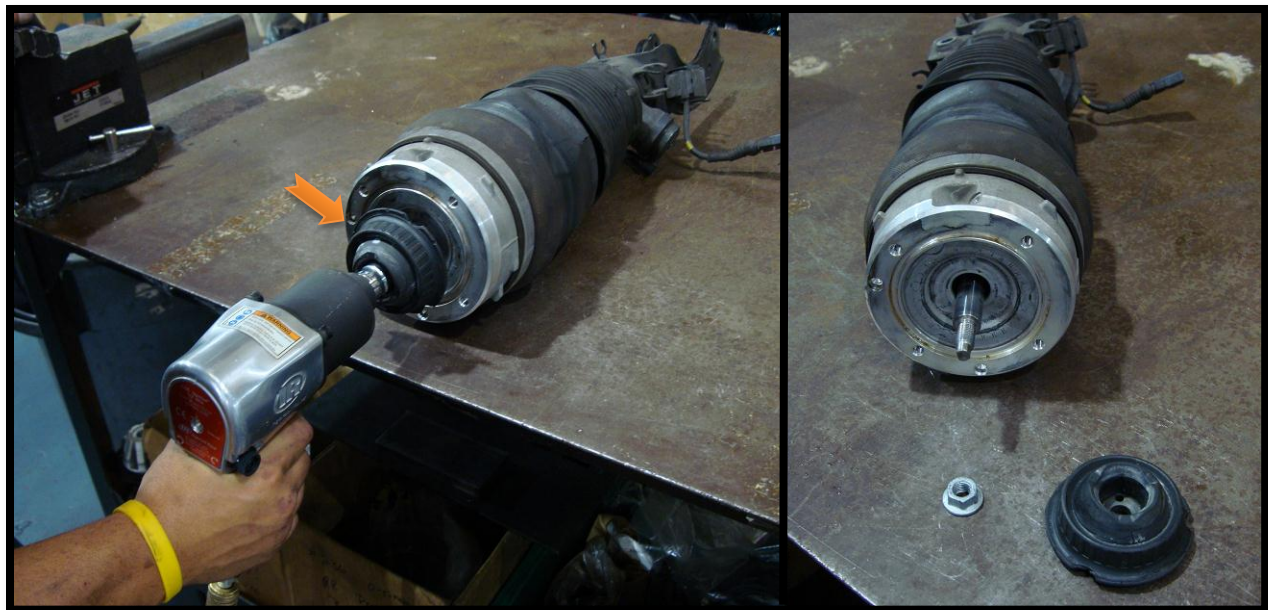

**Figure I**



14.0 Remove the bottom of the dust boot from the shock (Figure J).

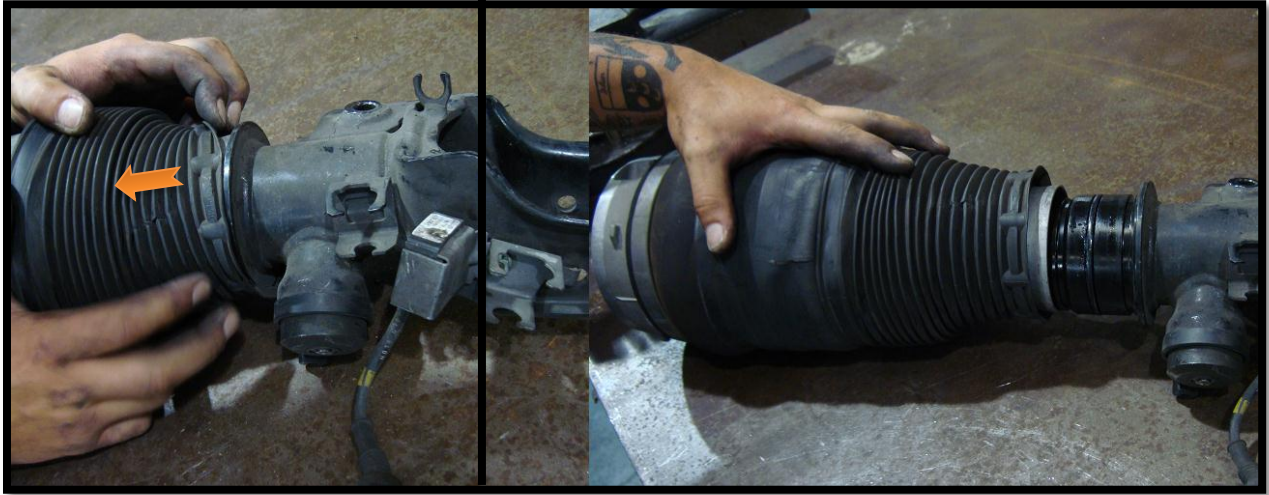

**Figure J**

15.0 Remove air spring assembly from shock. Remove the shock O-ring and discard (Figure K).

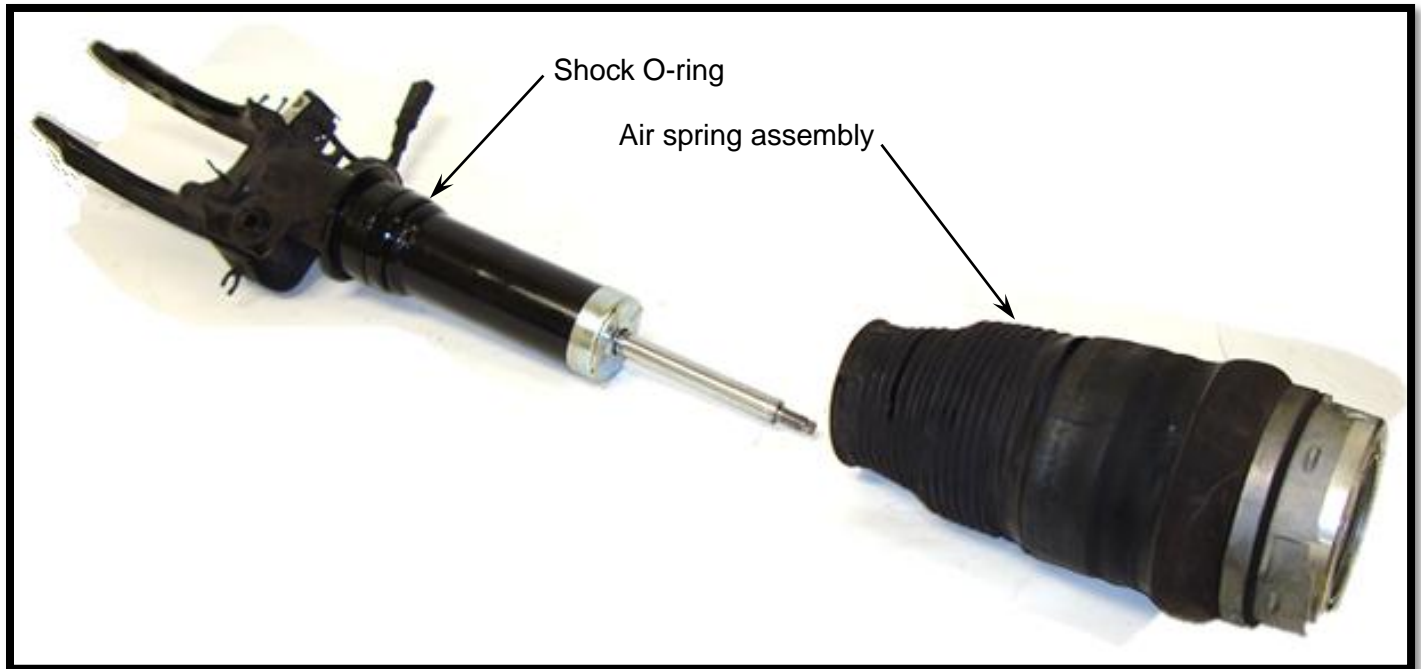

**Figure K**



- 16.0 Install new shock O-ring, apply lubricate to the O-ring. Use caution when installing O-ring, if damaged the air spring will not hold pressure. (Figure M).



**Figure M**

- 17.0 Install the bump stop onto the shock (Figure N)

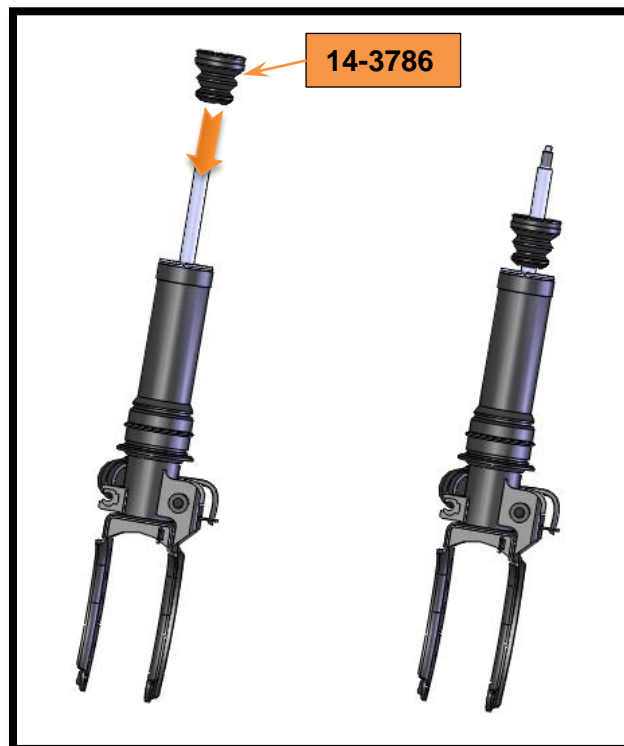

**Figure N**



18.0 Install the new air spring onto the shock (Figure O).

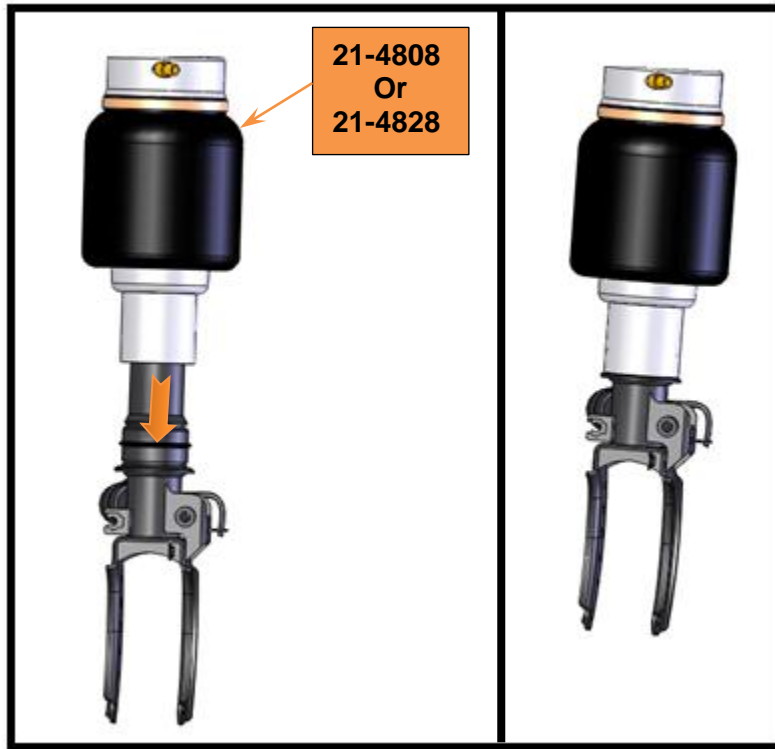

**Figure O**

19.0 Install the new rubber rod end mount and nut onto the shock, tighten to manufacturer's specification. Install the new O-ring onto the top mount (Figure P).

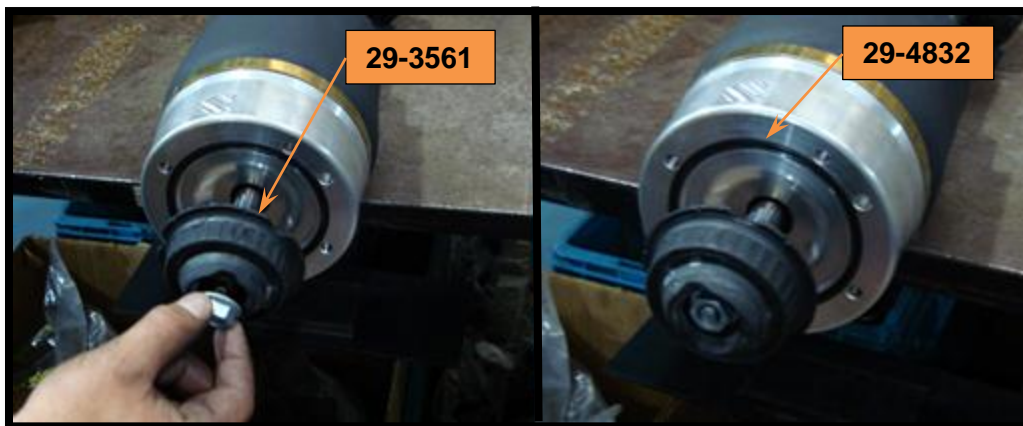

**Figure P**



20.0 Align the air inlet with the shock forks (Shown is a right side shock assembly, left side opposite) (Figure Q).

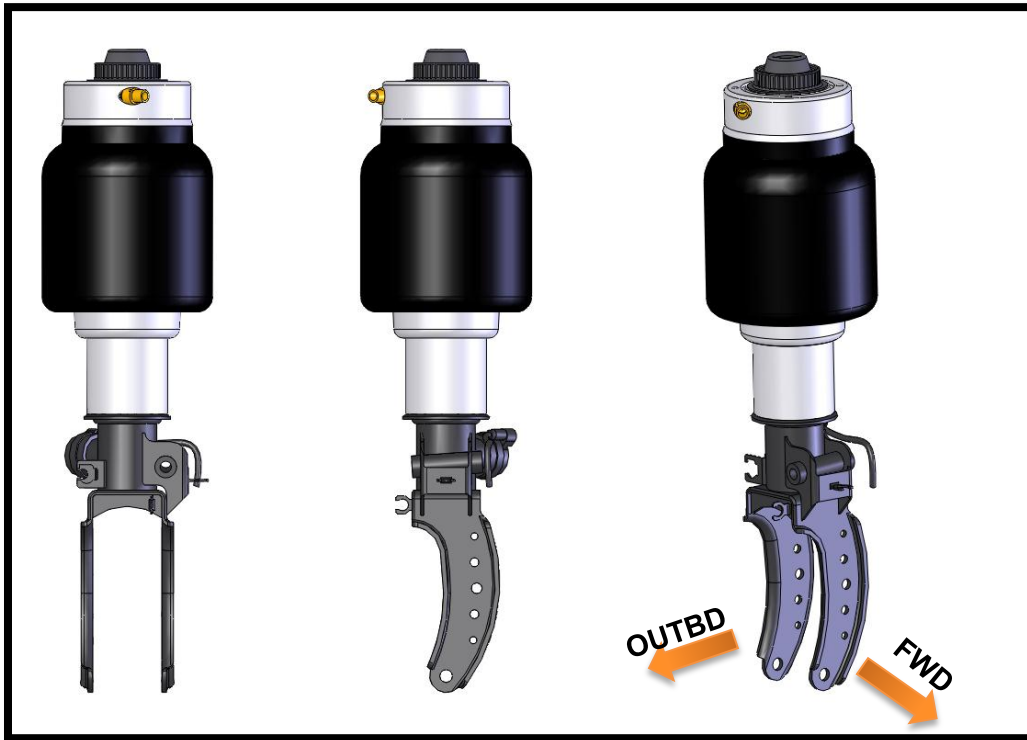

**Figure Q**

21.0 Install the new four bolts securing the shock to the shock mount; torque to 18-20 ft.-lbs. (Figure R).

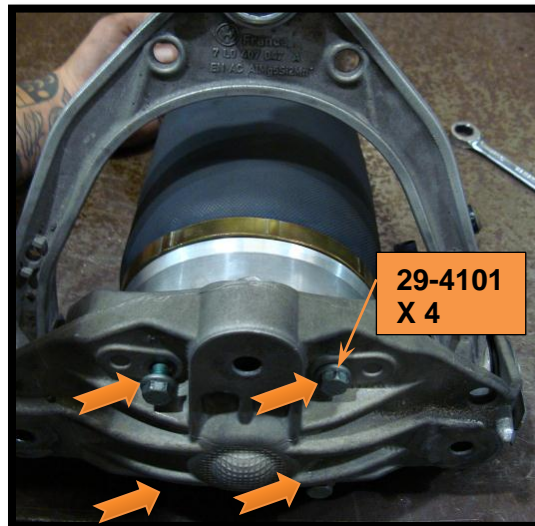

**Figure R**

22.0 Re-install shock into vehicle (reverse of removal steps); unless otherwise specified tighten all fastening hardware to manufactures specification.



**NOTE: Installation of the air line to the air fitting is to be performed as shown below.**

Air hose installation:

- 1.0 Remove the air line from the air fitting by removing the split ring collet and sliding the air fitting off the hose (Figure S).

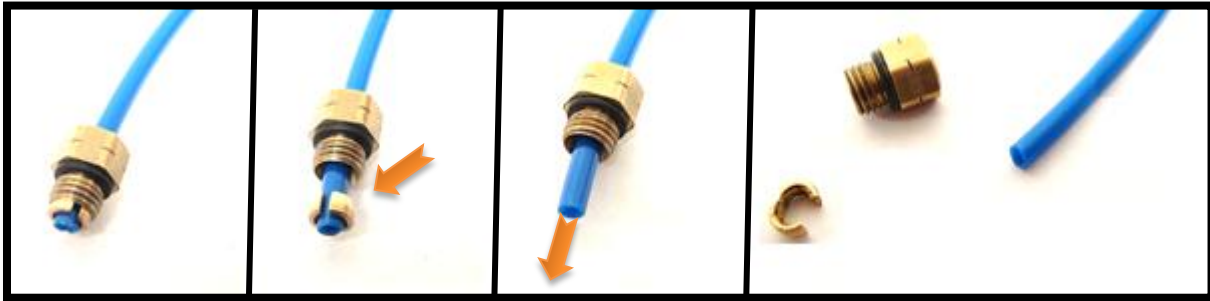

**Figure S**

- 2.0 Remove plastic pin from new air valve (Figure T).



**Figure T**

- 3.0 Push air hose into new fitting until it bottoms out; pull outward to verify hose is secure in air valve (Figure U).



**Figure U**



### Inflating air suspension system:

**NOTE: Verify that the “level control” fuse has been installed.**

- 1.0 Start vehicle.
- 2.0 Depress the ride height normal button. (Air springs will start to inflate) (Figure V).



**Figure V**

- 3.0 Exercise the air springs by raising and lowering the ride height (Figure W).



**Figure W**

- 4.0 Set ride height to personal setting.